

Innovations from Venti Oelde

100% increase in performance – New drying system for printing presses and coating plants

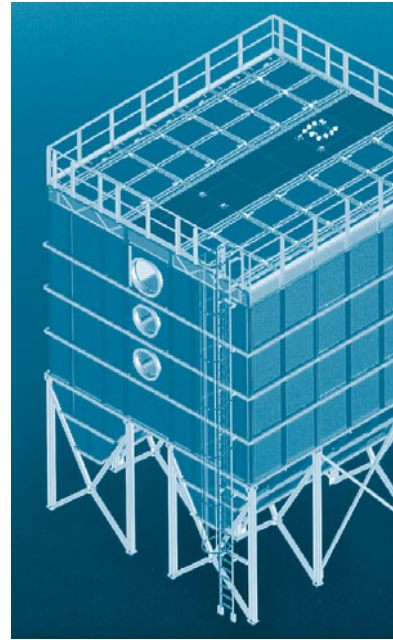
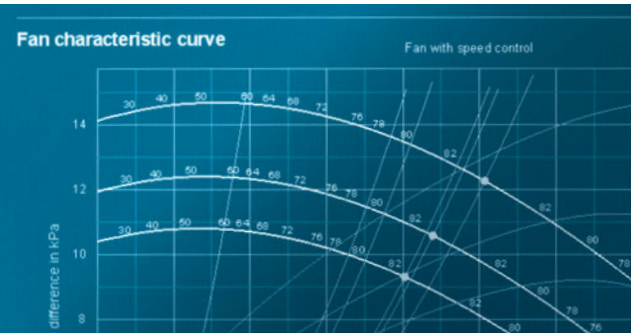

100 % increase in performance

New drying system for printing presses and coating plants

Using a new nozzle geometry Venti Oelde has improved the efficiency of drying systems for printing presses and coating plants. The patented process offers enhanced performance, better safety, higher quality – and also lower energy consumption.

Venti Oelde, the specialist for innovative air moving equipment for plants and components in numerous industries, has also been researching, developing, manufacturing and supplying drying systems for printing equipment and coating plants for decades. The ever growing requirements of customers regarding continuous convection dryers are met by the company with ever more efficient technology. The latest Venti innovation is a newly developed nozzle geometry with optimized air routing. Its use can almost double the drying capacity; it treats the printed or coated material gently, has been proved to save energy and ensures overall a higher process stability.

State of technology

With conventional nozzle dryers, the air curtain usually emerges from a parallel-sided outlet nozzle. It meets the material orthogonally (at right angles) at high velocity. This type of drying process often produces undesirable non-steady effects. This happens, for example, if the jets from neighbouring nozzles interact or if, as a result of the nozzle geometry, they are intrinsically unstable, which can induce web flutter, damage the surface of the material and finally damage the quality of the printed design.

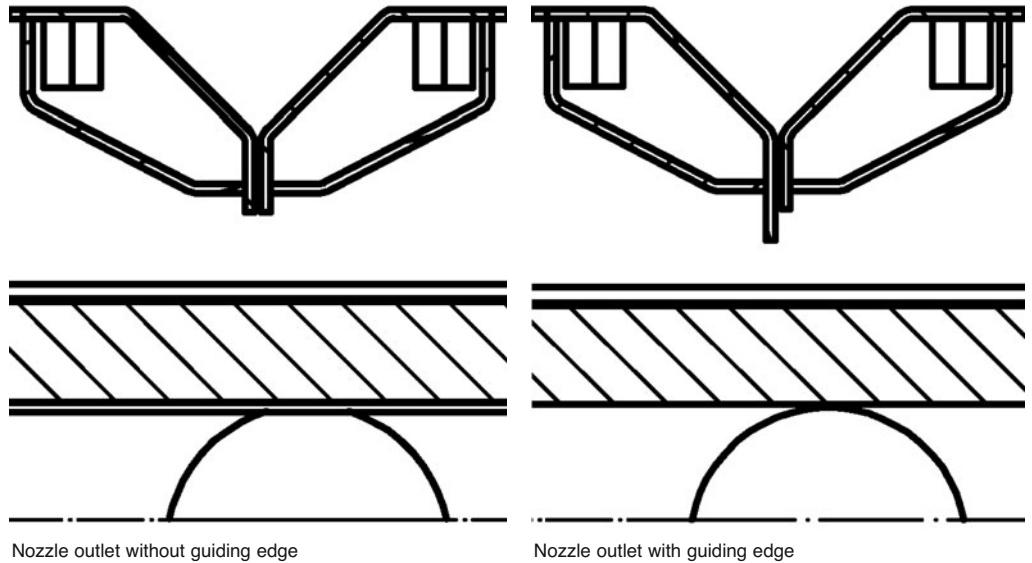

The new nozzle geometry

Venti Oelde has now added a guide device to the normal nozzle outlet. The outlet from which the air emerges has been equipped with a projecting guiding edge. This stabilizes the air curtain and ensures an ideal air flow onto the web.

This patented Venti Oelde technology offers a number of advantages. There is a significant improvement in heat transfer in comparison with the usual nozzle outlet without guiding edge. There is a correspondingly high increase in drying capacity. Simultaneously the maximum pressure at the stagnation

point decreases, which lowers web surface stress and relieves strain on the material. Both of these – improved heat transfer and reduced pressure – lower the required power input and current consumption of the blower drops. In addition, overall process stability is increased.

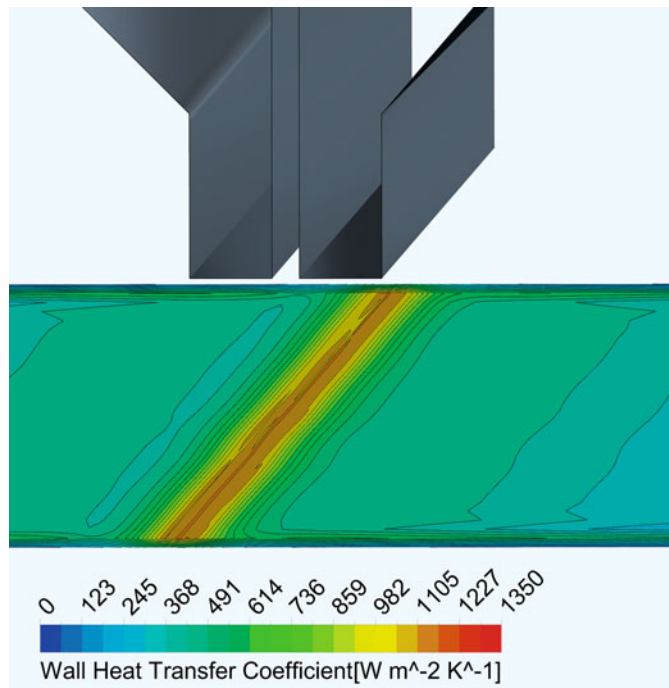

Heat transfer with nozzle outlet without guiding edge

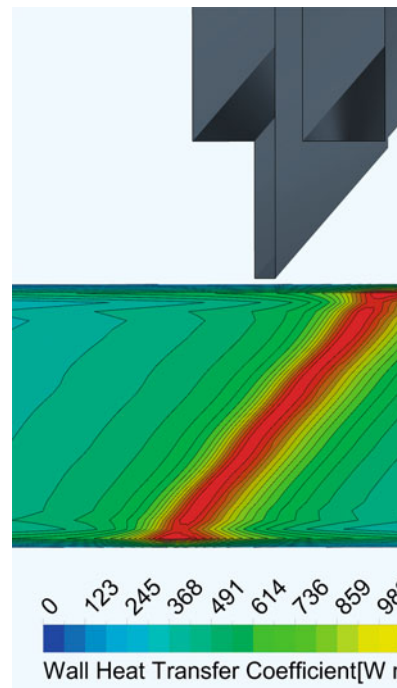

Improved heat transfer with nozzle outlet with

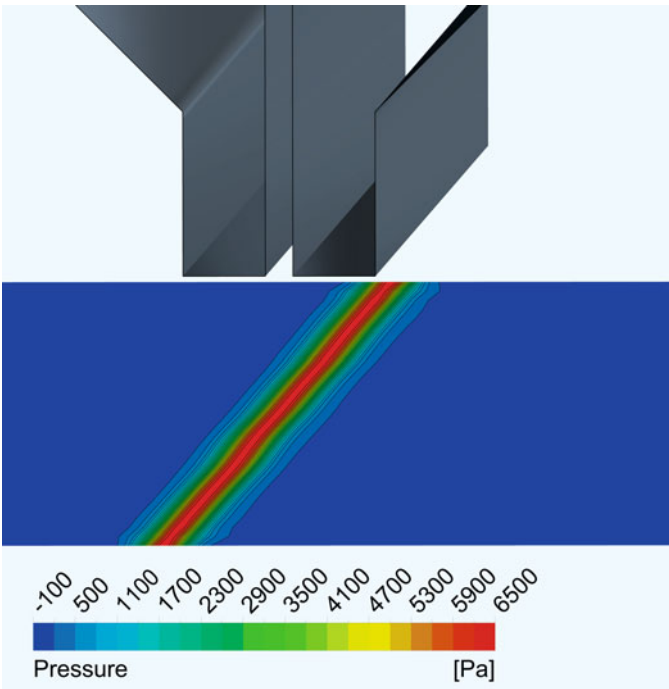

Pressure stress on web with nozzle outlet without guiding edge

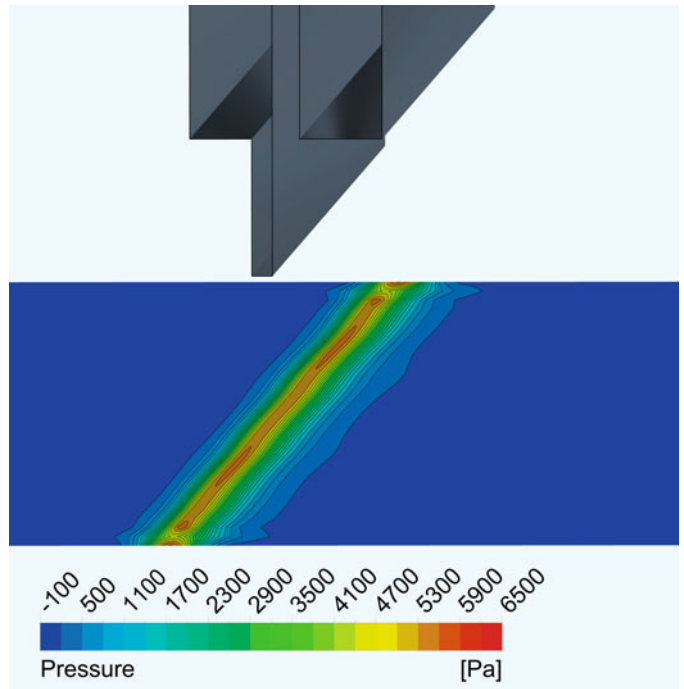

Reduced pressure stress on web with nozzle outlet with guiding edge

Simply more power

When the distance between the nozzle outlet and the web becomes wider, the weaknesses of conventional parallel-sided nozzles become increasingly obvious. The air curtain is sometimes unstable due to various influences, such as neighbouring nozzles impacting negatively on one another or because unavoidable factors from the surroundings reduce the drying efficiency. On the other hand, the new nozzle geometry with guiding edge proves its strengths when the distance between nozzle outlet and web increases.

The new nozzle stabilizes the air curtain and the air guided via the guiding edge meets the web much more evenly than with the conventional nozzle outlet. The adverse influences of the parallel air routing are practically eliminated in this way. When

there is a greater nozzle to web distance, the gain in performance is particularly noticeable. In such a case, the drying capacity will improve by up to 100 percent.

material and money. Furthermore, manufacturing inaccuracies, which were difficult to determine and to avoid until now, particularly with elaborate designs, are now practically eliminated.

Exactly what is needed

Venti Oelde can adapt the nozzle geometry precisely to the application. With the aid of its in-house computational fluid dynamics program (ANSYS CFX), the company can perform computer-aided comparisons of countless new nozzle geometries and establish in advance their behaviour under operational conditions. Until now numerous, time-consuming tests in the company's testing facilities were needed. These are now reduced to a minimum, since only the geometries which have been pre-selected by the CFD (computational fluid dynamics software) are tested. This saves time,

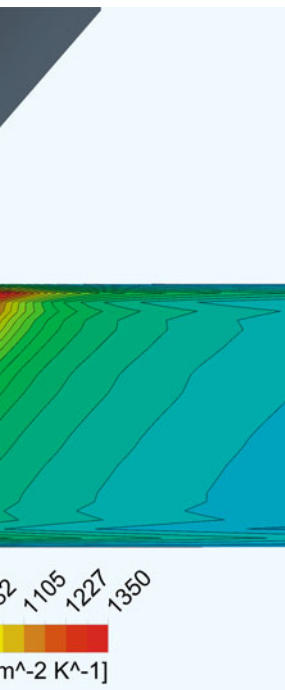

guiding

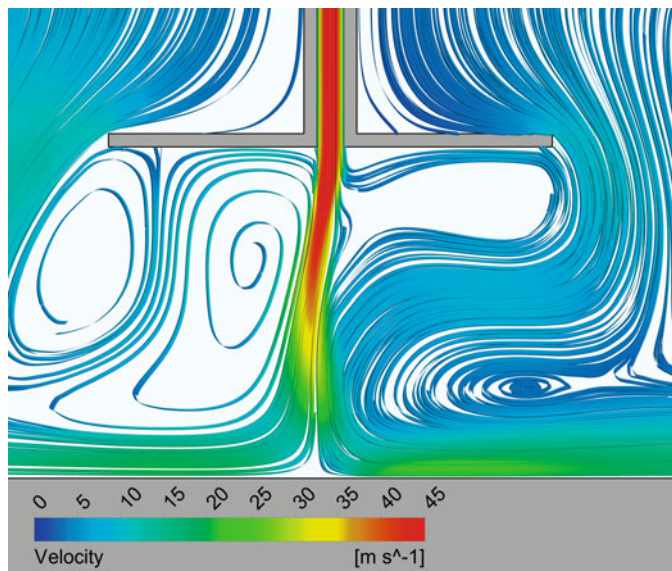

Unstable air curtain with conventional nozzle outlet

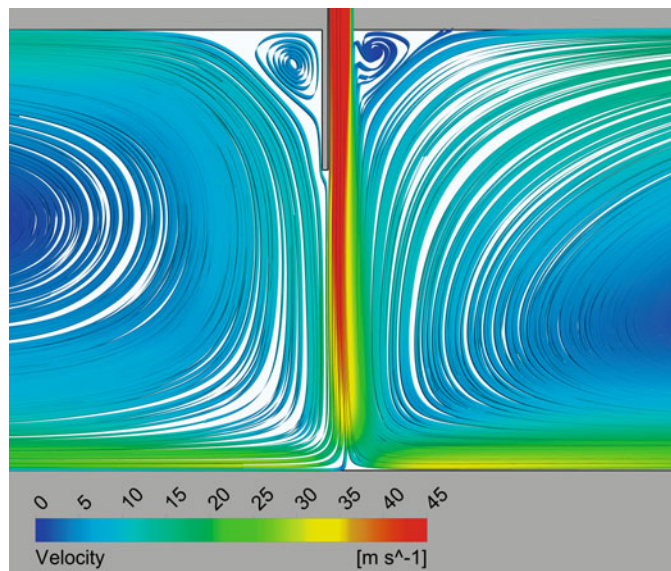

Stable air curtain with nozzle outlet with guiding edge

Proven in theory and practice

The theoretical results of the CFD simulation were then confirmed during the practical test. When checked in the testing facilities, the drying capacity was verified. Venti Oelde was able to positively corroborate the improvement

provided by the guiding edge nozzle. The nozzle with guiding edge instantly gave better drying results and improved drying performance by up to 100 percent. It offers a more flexible application range as well as considerably higher process stability.

Good for upgrading

The new nozzle geometry can not only be used in new plants. Existing plants can quickly and easily be upgraded by installing them. This gives manufacturers and users the opportunity of offering their customers considerably improved drying

systems, individually adapted to their production.



Ventilatorenfabrik Oelde GmbH
 P.O. Box 37 09
 D-59286 Oelde
 Phone: +49 25 22 75 - 0
 Fax: +49 25 22 75 - 2 50
 info@venti-oelde.de
 www.venti-oelde.com

- ▶ Industrial fans
- ▶ Dust collection and process air cleaning plants
- ▶ Exhaust air treatment plants
- ▶ Ventilating, heating and air conditioning plants
- ▶ Recycling and waste processing plants
- ▶ Surface technology