

Industrial Centrifugal Fans

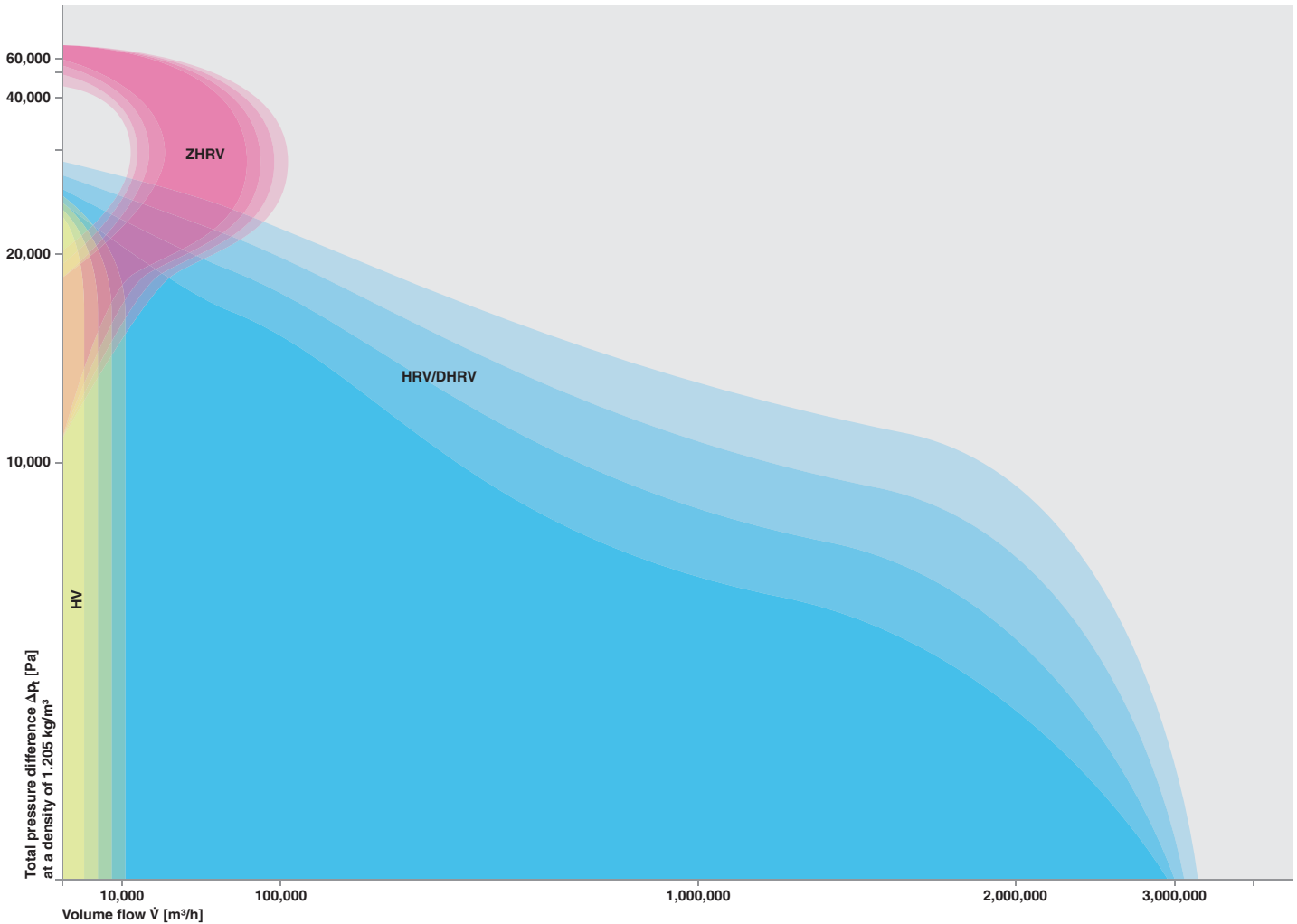

**Venti
Oelde**

Industrial centrifugal fans, recognizably Venti



Venti Oelde industrial fans are used to handle air, gas and vapours, with or without solids. They are durable, quiet and easy to maintain. They are in use in a wide variety of forms in almost all key industries.

Venti Oelde designs and constructs each centrifugal fan on the basis of the specific process parameters. The series HRV, DHRV, ZHRV and HV encompass volume flows from smaller than 5,000 to above 3,000,000 m³/h. The total pressure differences range from 1,500 to 65,000 Pa. A fan with optimum efficiency can, therefore, be found for any required operating point.

The operating data determine whether we build our centrifugal fans as single inlet, double inlet or multi-stage fans. Operating temperatures extend to 500 °C and higher. Impellers are overhung or mounted between bearings. The centrifugal fans are with direct drive, through coupling or with v-belt drive.



Venti Oelde's services start at the first contact and continue through to the provision of support during regular operation. From project work to assembly, including along the way the planning phase and engineering, a personal contact will always be available.

Even after delivery and assembly, Venti Oelde explicitly remains a partner for all customers. Venti Oelde specialists are there personally for all relevant work – during assembly and commissioning as well for maintenance and servicing. In addition customers can call us 24/7 on our service hotline under +49 (0) 171-195 57 50.

Arrangements

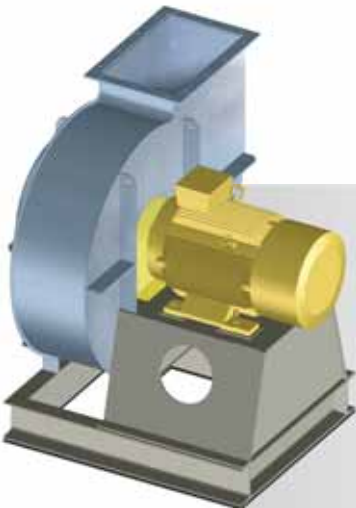

Arrangement M
Direct drive –
impeller on motor shaft,
shown with baseframe

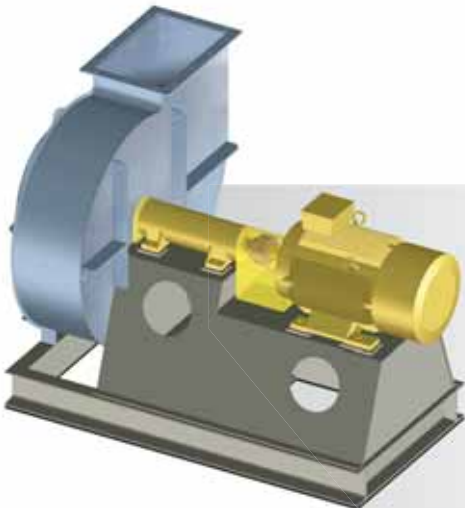

Arrangement K
Drive through coupling,
shown with baseframe

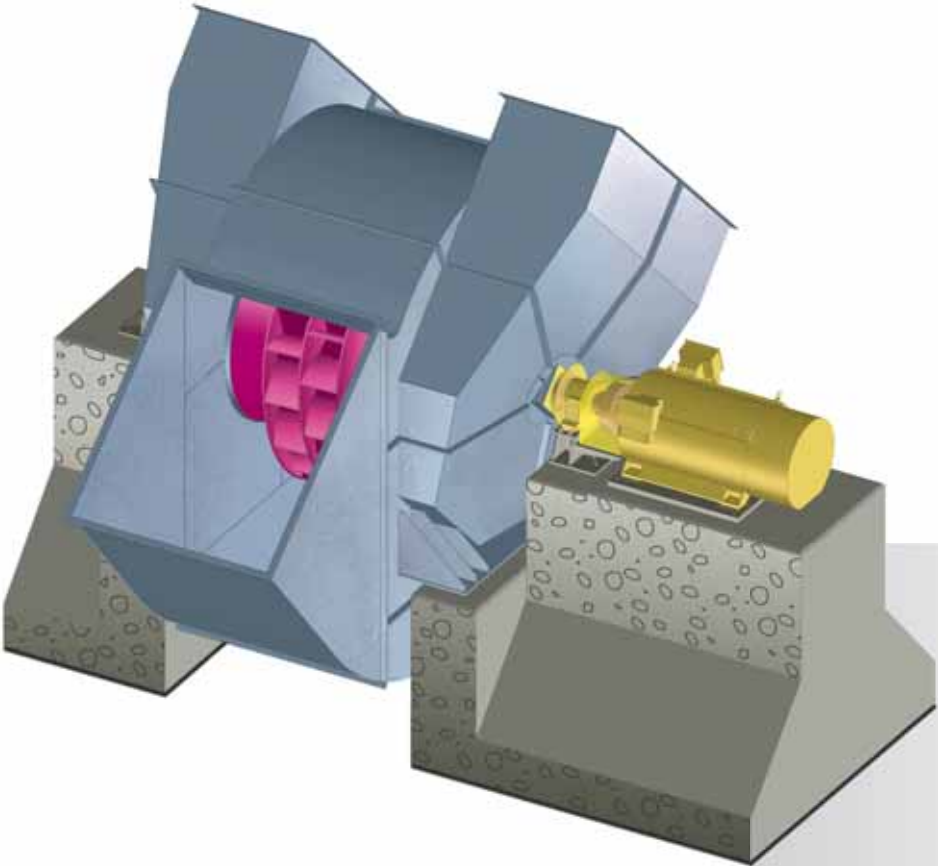

Double inlet centrifugal fan
Shown with raised
concrete foundation

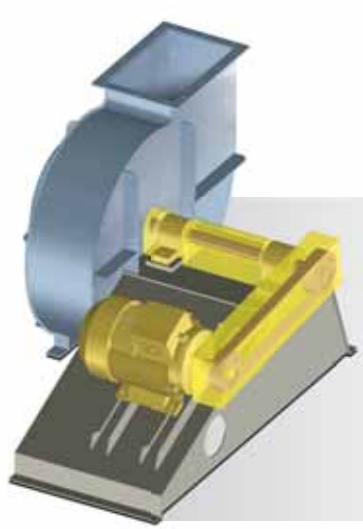

Arrangement R
V-belt drive

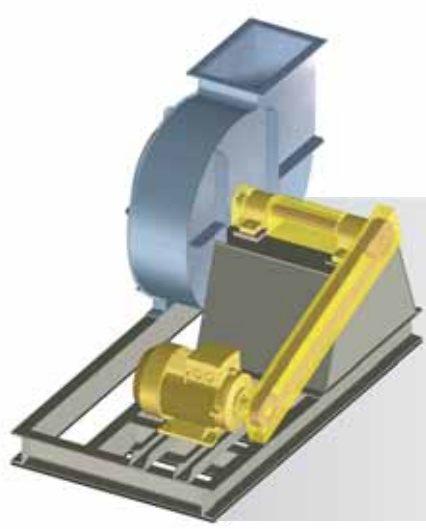

Arrangement RG
V-belt drive,
shown with baseframe

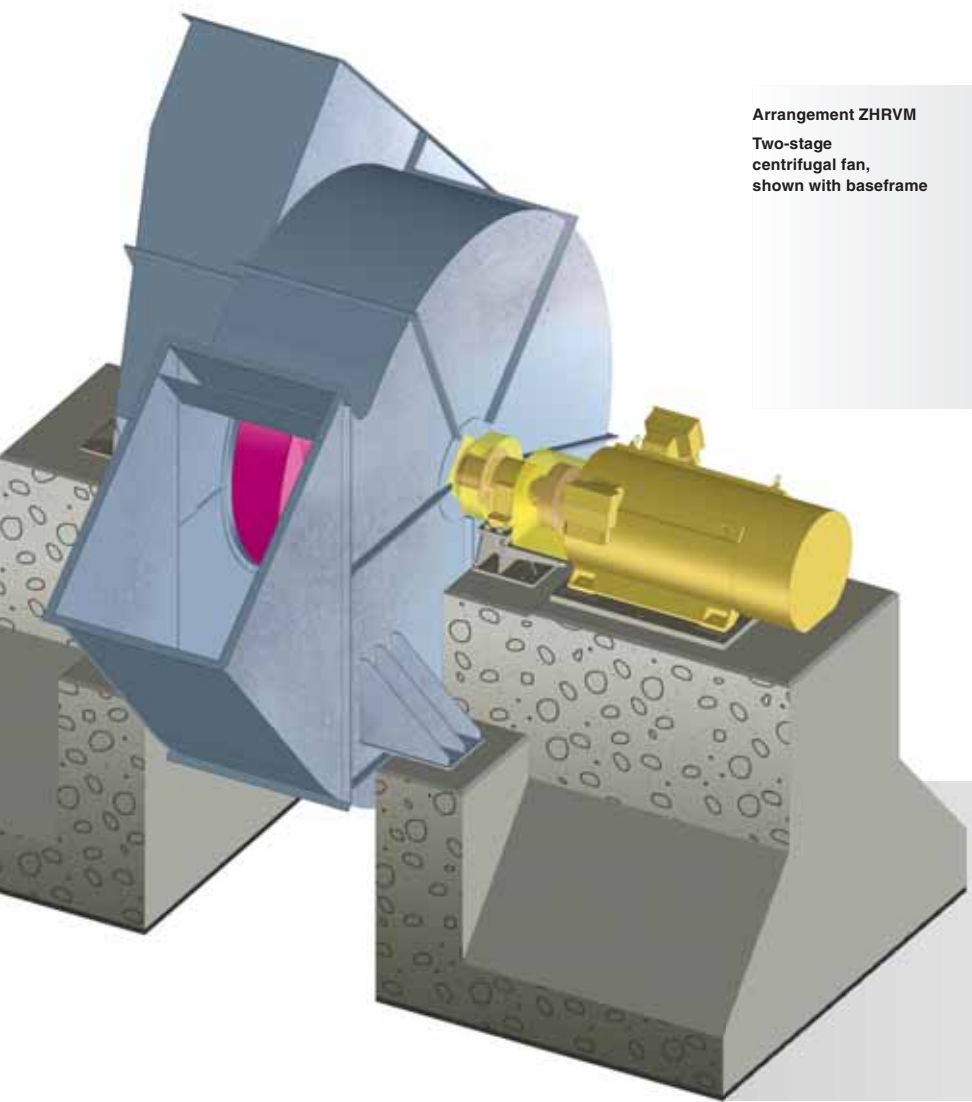

Single inlet centrifugal fan
Shown with raised
concrete foundation

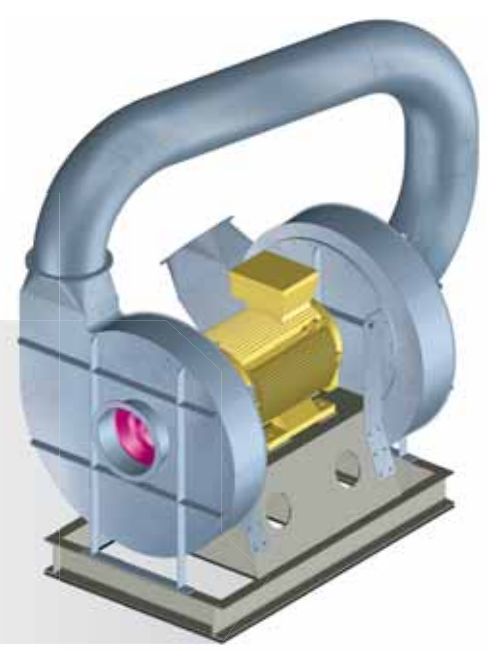

Arrangement ZHRVM
Two-stage
centrifugal fan,
shown with baseframe

Versatile in design and set-up

Depending on the operating data, our centrifugal fans are designed to be either single or double inlet, i.e. single-width or double-width. On the basis of the geometry, masses, speed and the expected load on the rotor, we determine, together with the customer, whether the impeller is to be overhung or

mounted between bearings. With double inlet centrifugal fans, the medium handled enters via inlet boxes that are flange-mounted to the fan inlet side or are directly welded to the volute casing.

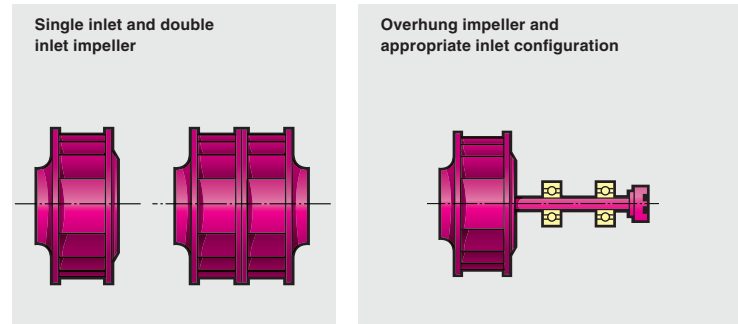

Possible outlet and inlet box positions anti-clockwise

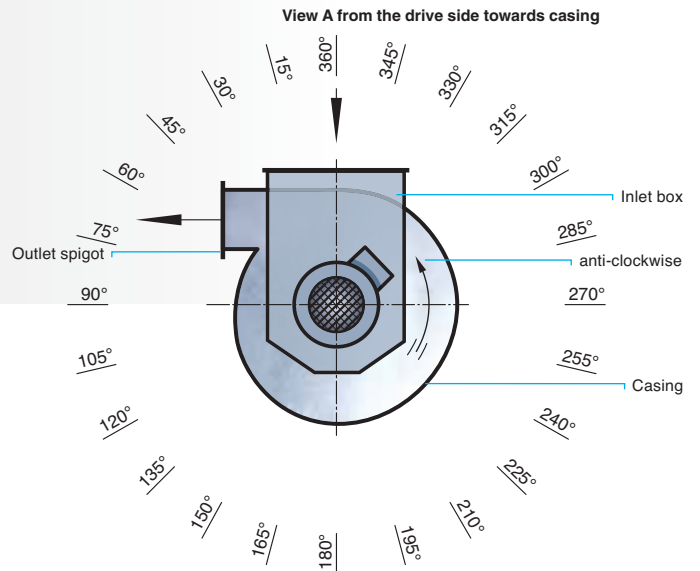
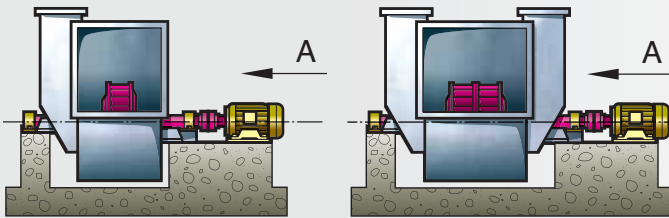

Possible discharge and inlet box positions clockwise

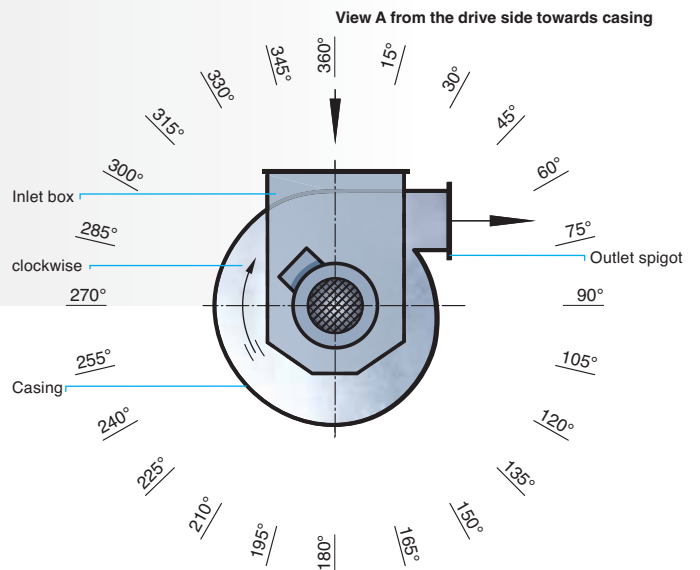
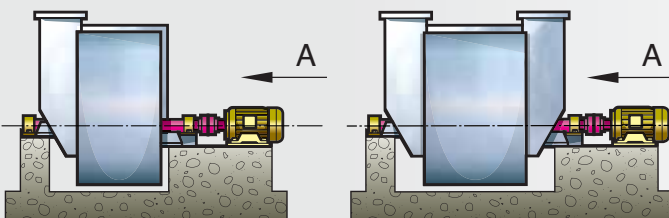

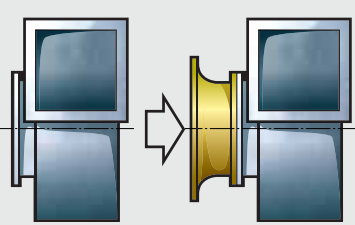

The inlet side of a fan with overhung rotor is configured with a flange-mounted duct or a shaped inlet, possibly including an interposed damper.

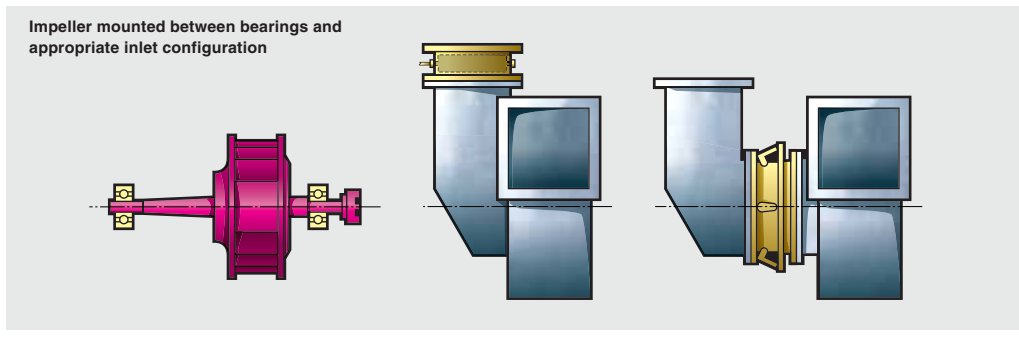

Air flows to rotors mounted between bearings through inlet boxes. The dampers are arranged as multi-bladed louver dampers in front of the inlet boxes or inlet vane controls downstream of the inlet boxes.

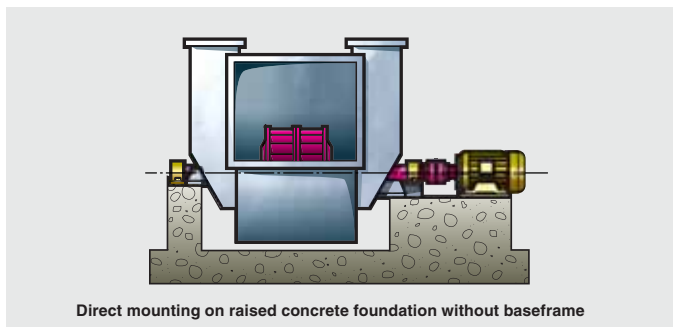
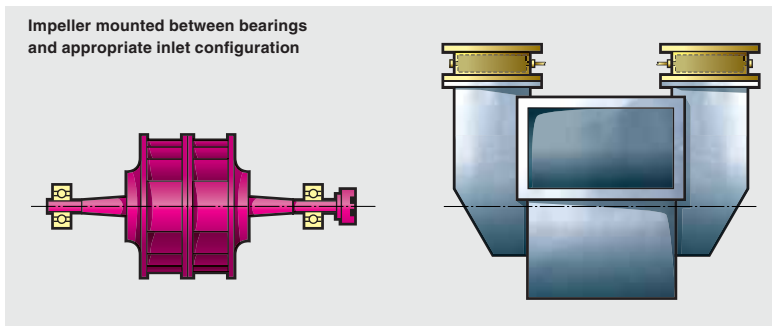

Direct mounting on raised concrete foundation without baseframe

Mounting industrial fans on a concrete foundation ensures high torsional stiffness and negates the need for a welded motor pedestal. Recessed foundations or raised concrete foundations are suitable. Anchoring the fan directly to the raised concrete foundation is preferable to the steel construction particularly if, as a result of the operational conditions, rotor unbalance is to be expected. If required, we can almost completely eliminate dynamic interaction between fan and base by fitting vibration dampers between them.

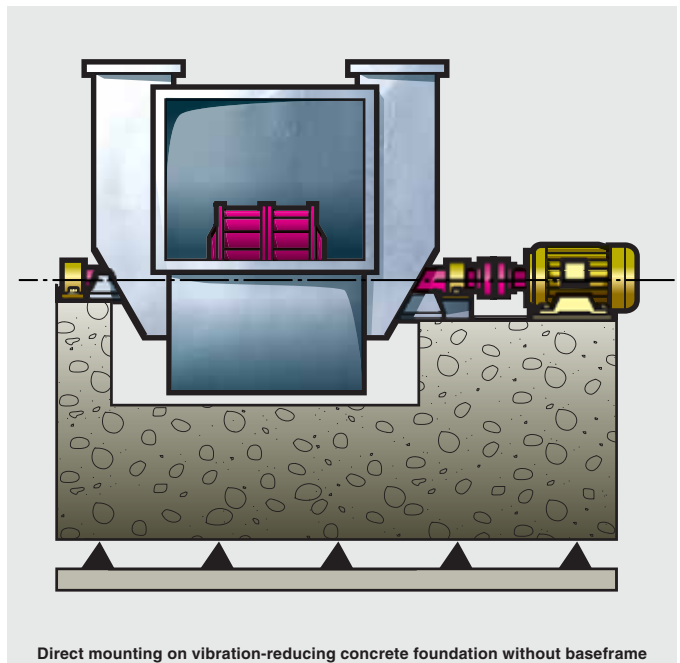

Direct mounting on vibration-reducing concrete foundation without baseframe

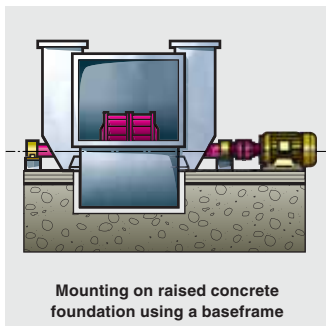

Mounting on raised concrete foundation using a baseframe

Impeller geometry and blade shape for every application

Backward
curved blades

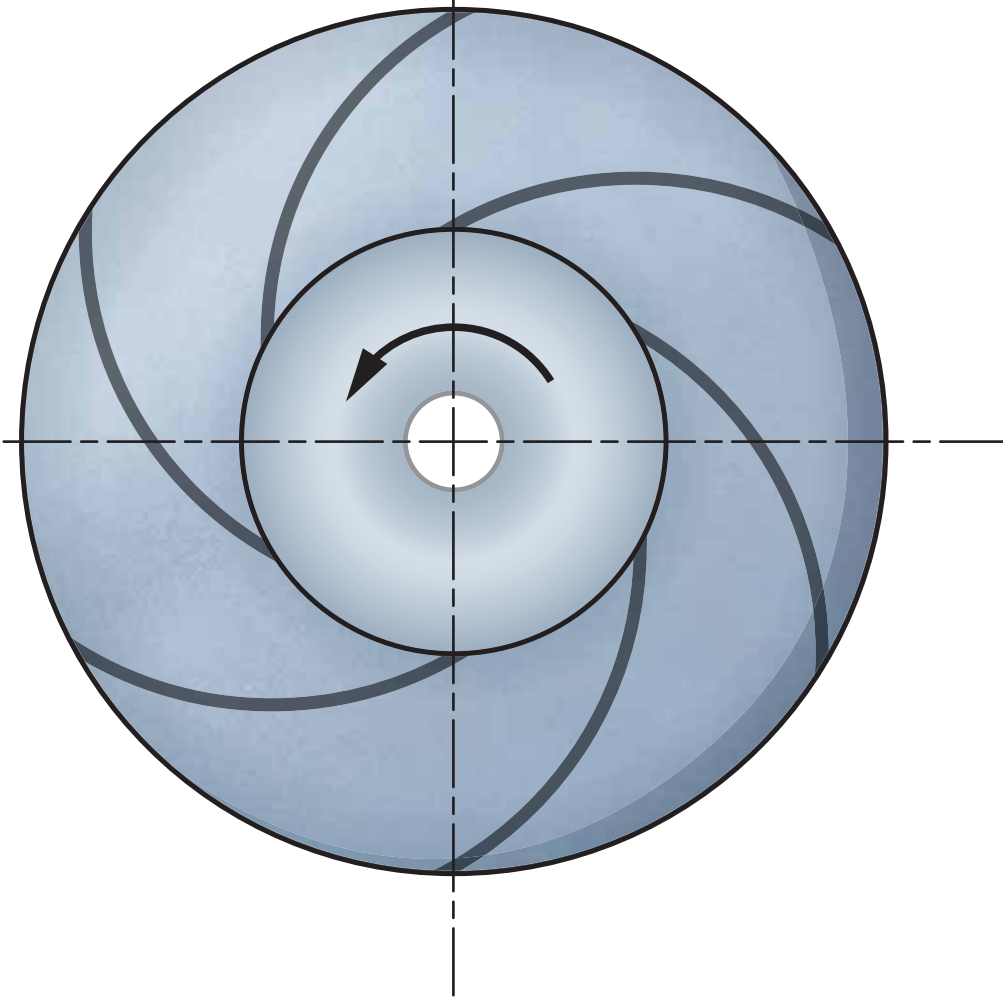

Logarithmically backward
inclined blades

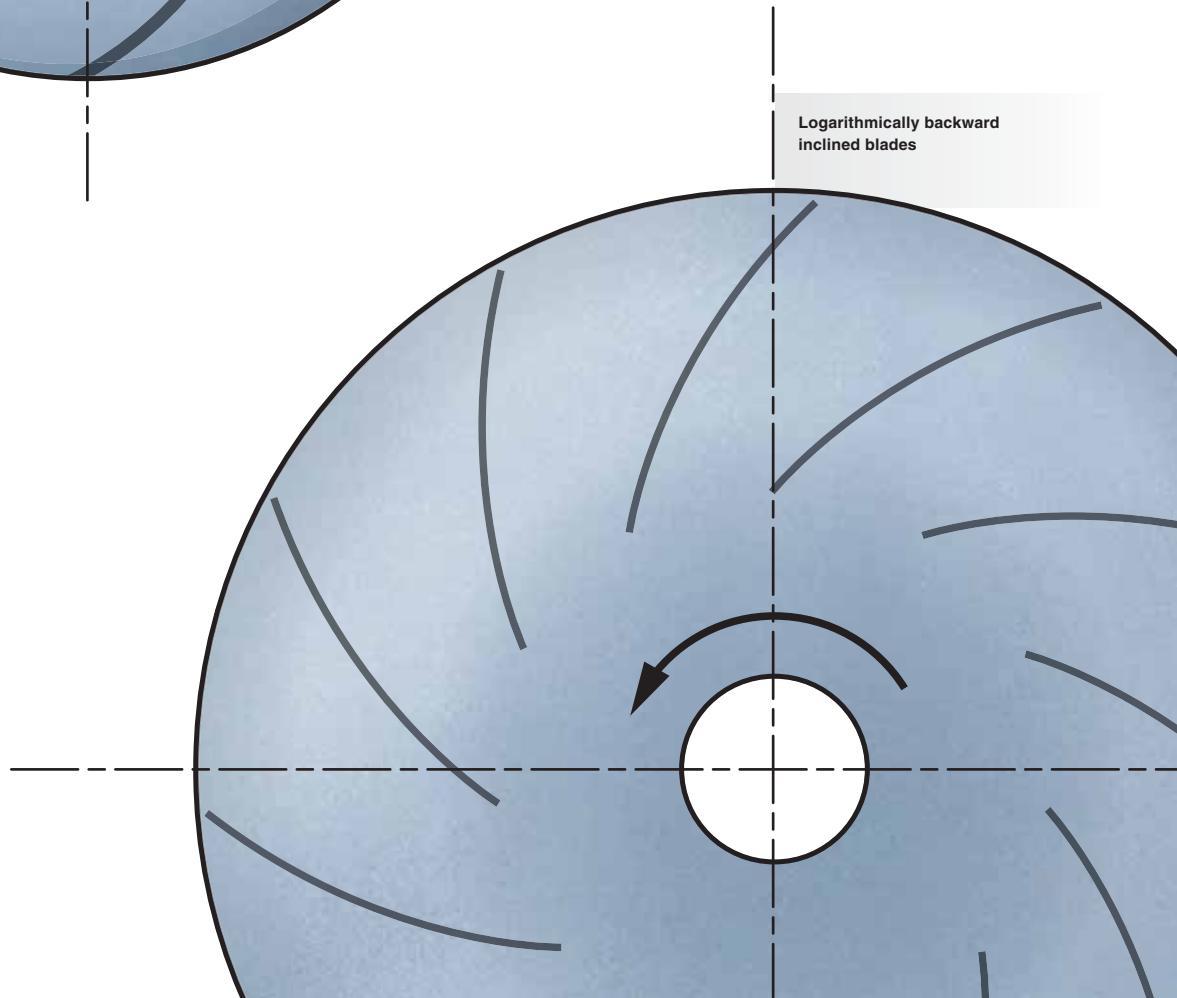

Straight, radial-tipped blades

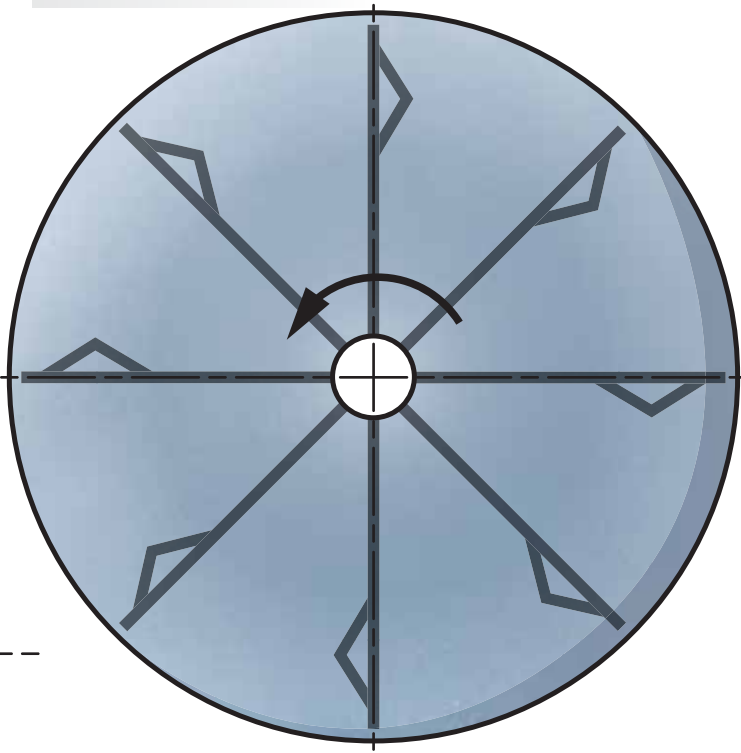

Forward inclined blades

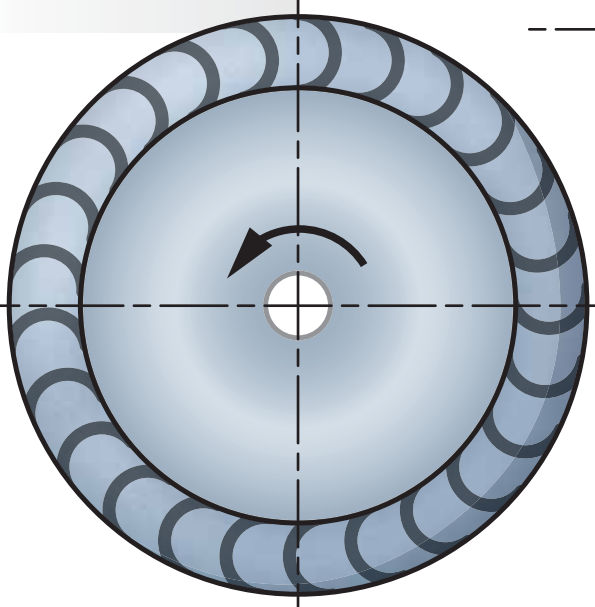

Aerofoil blades

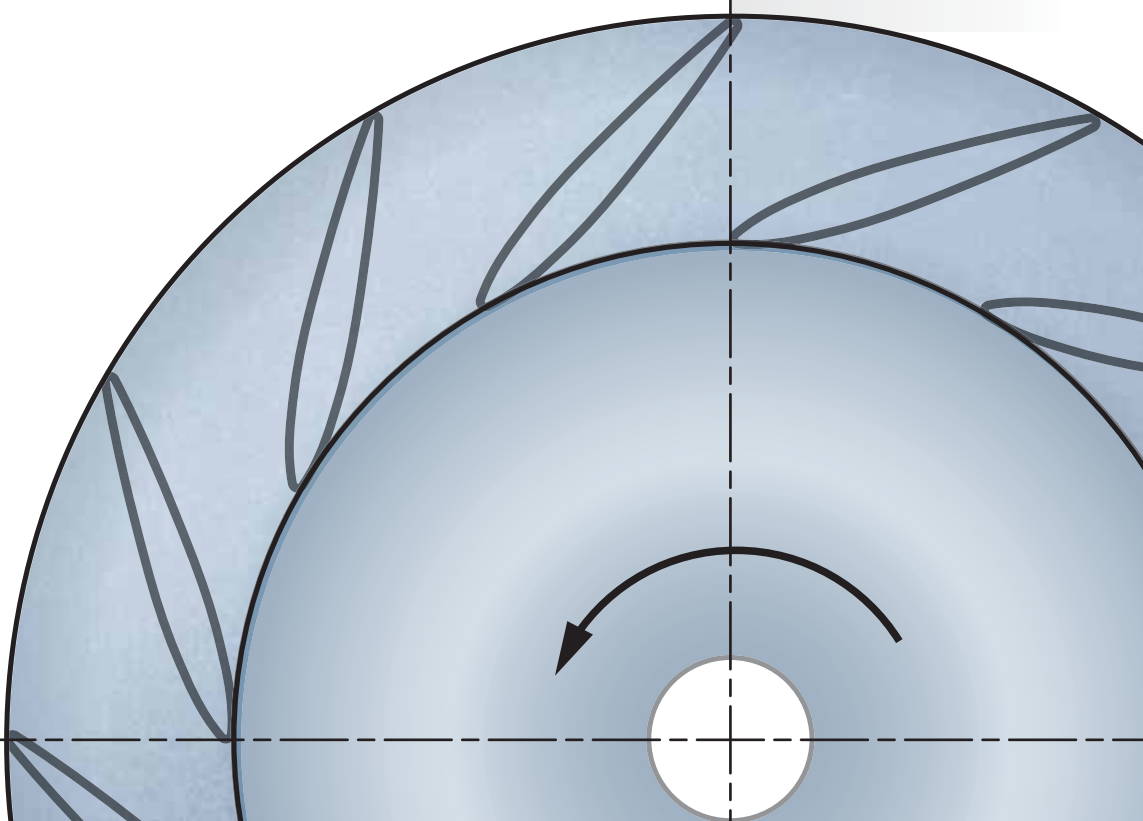

Designs and special solutions which count



Shaft with journal bearing seat and pre-mounted shaft seal, coupling with axial backlash limitation

Bearing housing of a self-aligning roller bearing with cooling impeller and pre-mounted shaft seal





We fit our fans with bearings supplied by reputable manufacturers. When hot gases are being handled, cooling impellers between the casing and bearing ensure the removal of residual and creeping heat. In critical cases, oil-circulating lubrication provides additional bearing cooling.



We also use external oil supply systems for the lubrication of bearings and drives; if required, in compliance with API Standard 614.

Rotor turning gear units are used to slowly rotate the fan when maintenance work is due or to permit the fan to slowly and uniformly cool down when the main drive has been switched off. The chosen rotating speed is normally very low, but sufficient to maintain lubrication of the fan bearings.



Drum brake

Drum and disc brakes serve to shorten the run-down time when the fan has been switched off and to retain the fan when it is at a standstill.

Disc brake

Designs and special solutions which count

Venti Oelde also designs the shaft seals individually according to the specific plant operating conditions; if required, multi-chamber labyrinth seals with sealing gas connection are used. Sealing the shaft passage through the casing prevents dust or toxic gases escaping or ambient air contaminating the medium handled.



Venti Oelde combats wear caused by friction and impact to impellers and inside casing walls with a variety of measures. Effective protective procedures are decided during the fan planning phase with the goal of prolonging service life by using suitable materials, high-precision machining and optimum blade geometry.

Disc seal

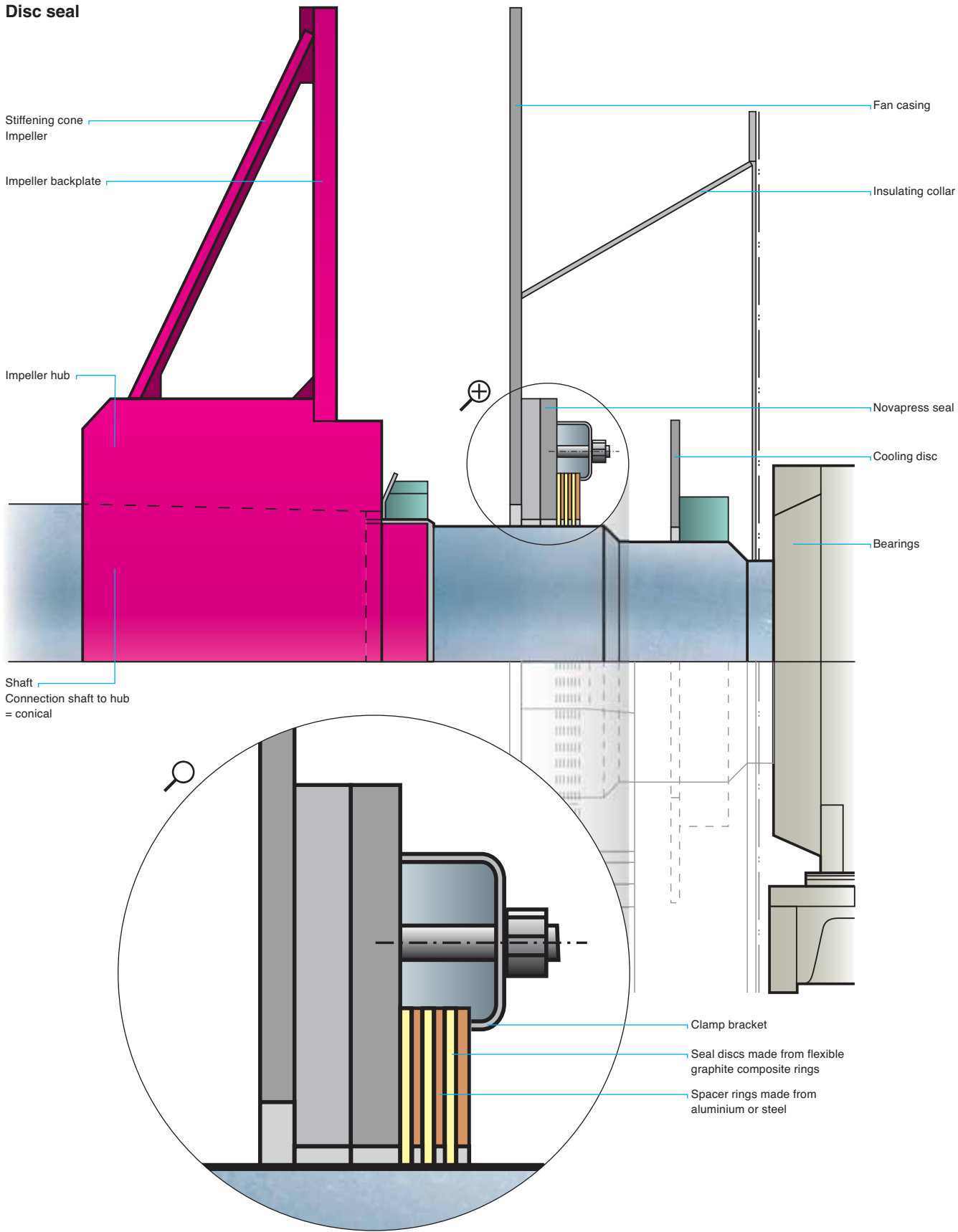

Value-added accessories

If specified, we can almost completely eliminate dynamic interaction between fan and base by fitting vibration dampers between them. Vibration dampers, together with flexible joints, ensure decoupling between the fan and connected systems.

Finally, Venti Oelde's electronic monitoring systems reliably provide cost-effective preventive maintenance and service. Vibration monitors control the oscillation amplitude and give early warning of any dreaded material caking in the fan. Our dynamic balancing systems reduce any imbalance and vibrations by mass balancing.



Variable speed motors, lower dampers or inlet vane controls serve to adapt the gas volume flow to the needs of the connected system.



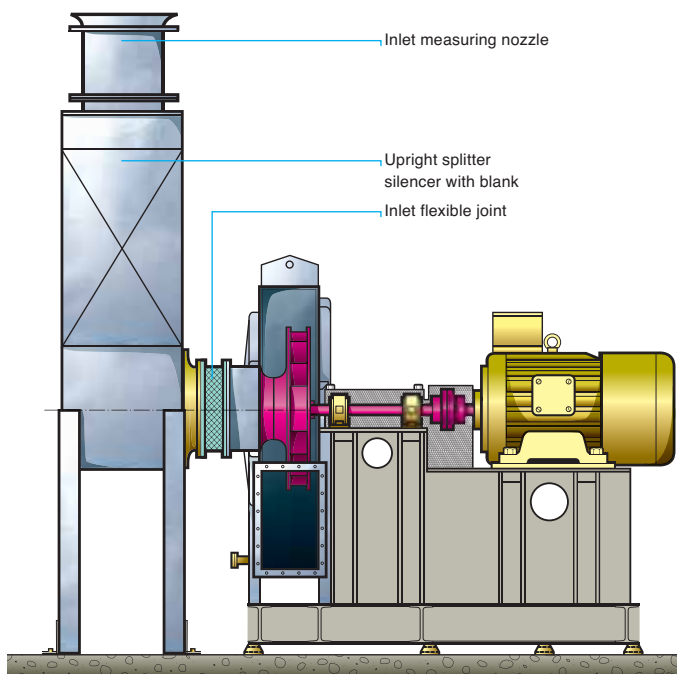

Flexible joints decouple the fans from the ducting system. A suitable fabric for the flexible joints is selected to fulfil demands made by the medium handled. The chosen fabric is usually neoprene, silicone-glass or PVC-polyester. Steel flexible joints have proved particularly successful with difficult media.

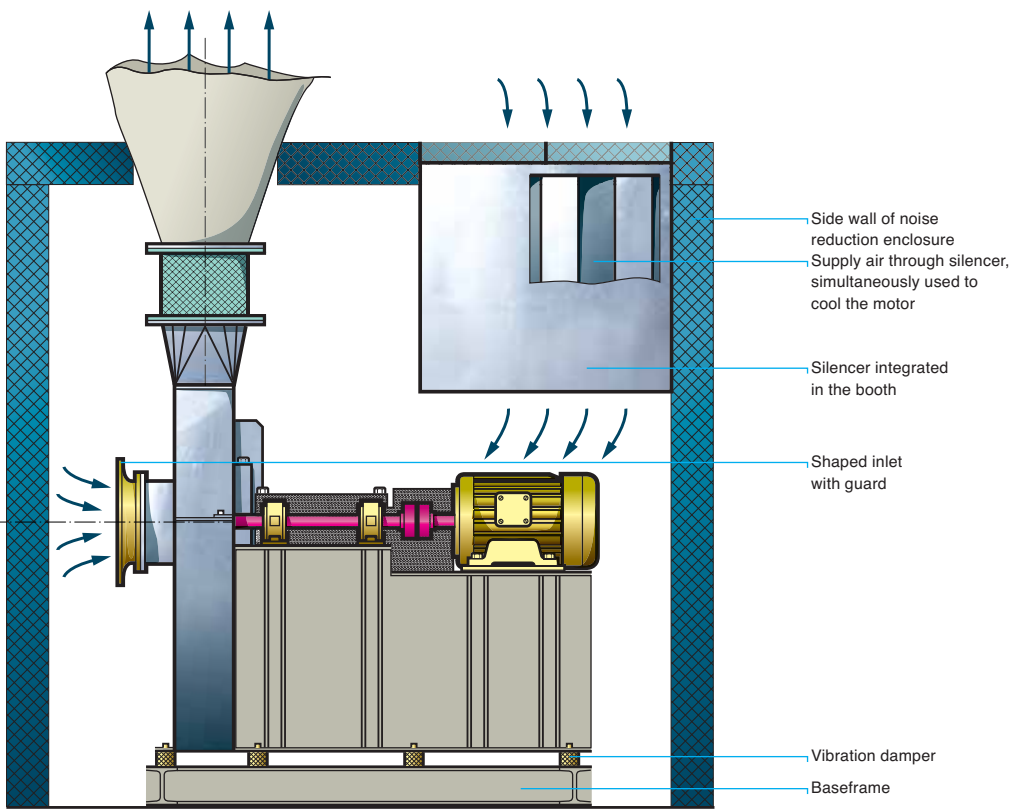
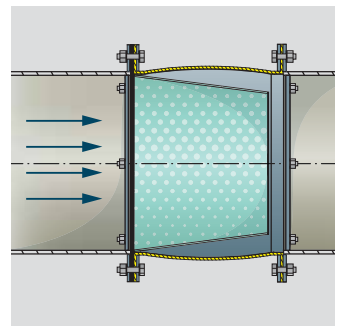

Venti Oelde offers made-to-measure noise protection: All major components of our fans are acoustically optimized by our own technical designs. Individual noise control measures simultaneously provide insulation against heat loss. Venti Oelde thus offers particularly budget-friendly solutions.

Additional measures can be taken, such as the insulation and decoupling of structure-borne noise from foundations and connections. Carriers of emissions to the outside, like fresh air intake ducting and stacks can be insulated, for example, by means of silencers. Of course, fans and drive units can also be completely enclosed.

My request for quote from Venti Oelde

Company _____

Street _____

Post Code/Town/Country _____

Contact _____

Phone/Email _____

General information

Site _____

Altitude above sea level _____ m

Air pressure _____ Pa

Ambient temperature max. _____ °C

min. _____ °C

Service voltage _____ V

Frequency _____ Hz

Design data

Application _____

Volume flow _____ Am³/h

Operating temperature _____ °C

max. temperature _____ °C

Pressure difference static total

_____ Pa _____ Pa inlet

Medium handled _____

Density _____ kg/Nm³/h

Dust content _____ mg/Am³ Type of dust _____

Noise specifications Sound pressure level _____ Lp (A) dB (A) at a distance of 1m or

Sound power level _____ Lw (A) dB (A)

Other _____

Arrangement

Single inlet Double inlet

Steel pedestal Baseframe

Bearing pedestals on raised concrete base Bearing pedestals and motor soleplate on raised concrete base

Other _____

Scope of supply

Control element Flexible joints

Vibration dampers Vibration monitoring

Motor

Silencer Noise insulation

Other _____

Additional information

By fax, smartphone or PC



Please complete the questionnaire, tear out along the perforation and send it to us at:

00 49 (0)25 22-75 523.

We shall answer promptly.



Scan the QR Code* with your smartphone or tablet and you will be directed to our online questionnaire.

*QR Code scanner app is required.

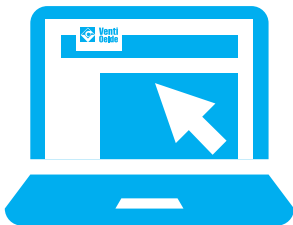

The questionnaire is also available to complete online at:

www.venti-oelde.com/ICF_Questionnaire

- Industrial fans
- Dust collection and process air cleaning plants
- Exhaust air treatment plants
- Ventilating, heating and air conditioning plants
- Recycling and waste processing plants
- Surface technology



Ventilatorenfabrik Oelde GmbH
P.O. Box 37 09
D-59286 Oelde
Phone: +49 25 22 75 - 0
Fax: +49 25 22 75 - 2 50
info@venti-oelde.de
www.venti-oelde.de